

A 50 mm return should be allowed at joints with the ridge purlin, plate, wall, etc. This return should be made tight by applying Aluthermo® adhesive, if the surface is smooth, dry and clean, or a sealant on rough surfaces.

The laths that will carry the final finish are then fixed on to the frame (wood panelling, plasterboard, etc.). The laths will crush the Vapreflex® at the purlins or other joints.

3.2.2. JOINTS WITH ROOF WINDOWS

To cut down the thermal bridges around roof windows, we advise applying thermal insulation continuously around the frames. It is not always easy to create one or two air spaces around the sash. We advise making a single Vapreflex® return at right-angles to the trimmer as far as the bottom of the sash. Fill the joints at right-angles to the corners with the adhesive aluminium tape. The closing face should be inserted into the sash and pointed around the periphery.

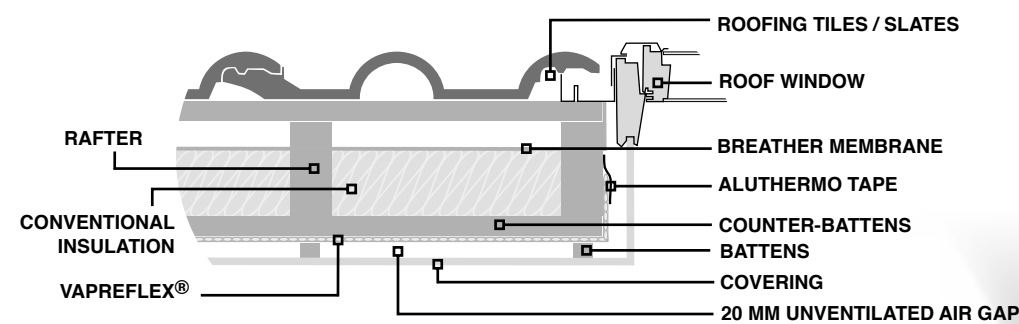

3.2.3. JOINTS WITH VENTILATING DUCTS, AERIALS, ETC.

Mark out the location on the Vapreflex® and cut the Vapreflex® along the two diagonals. Fold back and glue the edges with Aluthermo® aluminium adhesive.

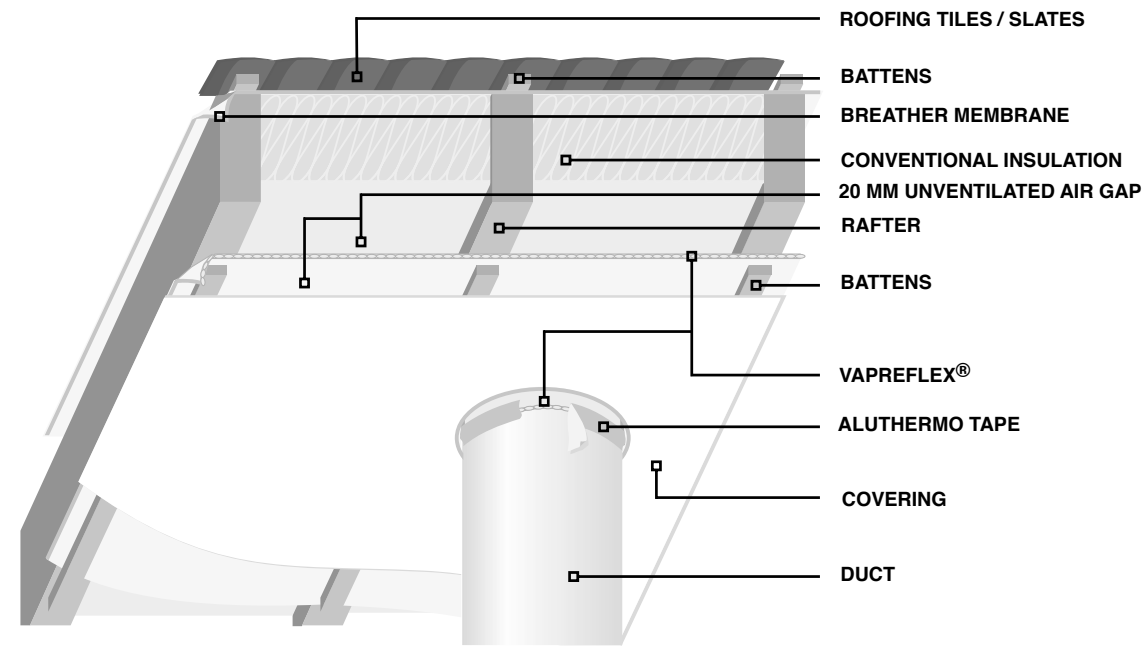

3.2.4. CHIMNEY JOINTS

If the exterior temperature of the chimney is likely to exceed 80°C, do not apply Vapreflex® within 200 mm of the chimney. The gap can be filled by a non-combustible insulating material.

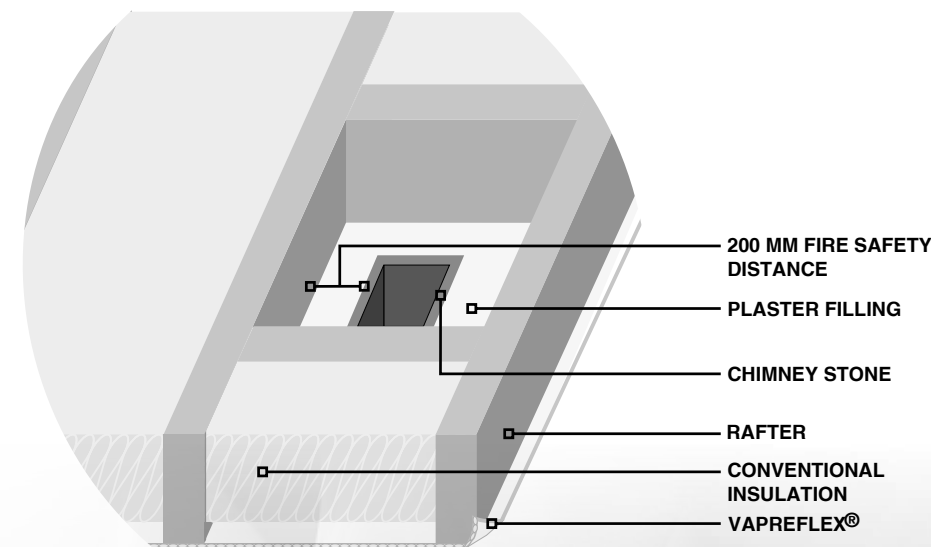

TECHNICAL INSTALLATION INSTRUCTION

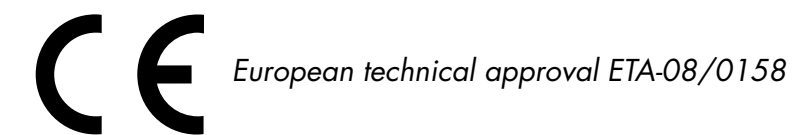

product of **ALUthermo®**

1. DESCRIPTION

Vapreflex® is a vapour barrier which provides additional insulation, comprising two layers of air bubbles sandwiched between two 12 µm thick films of pure aluminium.

Vapreflex® is designed to increase the temperature stability of insulating construction systems for attics and walls.

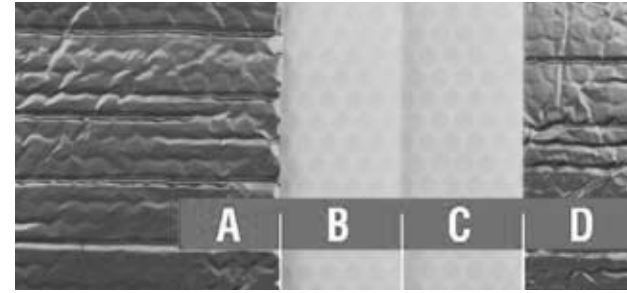

SAFETY PRECAUTIONS AND RECOMMENDATIONS

- **Vapreflex® is a Vapour Barrier** which provides additional insulation with a very high reflective power. It should always be fitted on the inside, i.e. the warm side, as a complement to additional insulation. It must not be pierced to allow tabs or T-hangers through.

- **Tightness to water vapour and air**

To protect the conventional insulation from water vapour and to limit energy losses, Vapreflex® must form a tight skin. This is easy to achieve. Vapreflex® should be unrolled across the whole area of the building, on the warm side. It can be unrolled horizontally or vertically according to the orientation of the frame and it should be provisionally fixed in place with 14 mm staples. The Vapreflex® strips should overlap one another by 50 mm. 75 mm Aluthermo® adhesive is applied to achieve tightness. Once it has bonded, the adhesive should be rubbed over with a dry cloth to ensure complete adhesion.

As Vapreflex is heat bonded over its whole area, cuts can be made anywhere. It can be cut with a standard cutter.

- **Unventilated air spaces**

To maximise the insulating power of Vapreflex® with respect to radiant energy exchanges, it should be fitted between two unventilated air spaces of at least 20 mm. The unventilated air spaces are created on the outside by combining Vapreflex® with conventional insulation, and on the inside by the finishing coat (plasterboard, wood panelling, etc.). Vapreflex® is always stretched and stapled to its support. In straight sections the distance between clips should not exceed 200 mm. At right-angles to junctions between widths, returns on purlins or floors, staple every 50 mm.

- Keep a **safety gap of 200 mm minimum to any heat source** higher than 80°C. Don't use Vapreflex® for the insulation of chimneys, inserts or heat exchanger.

- **Avoid direct contact with copper, lead or zinc** to prevent chemical reaction

- **Vapreflex®,** since it is built up with aluminium, **has to be earthed**

- **Don't use Vapreflex® in conjunction with down-lighters** or recess lighting that gives out a temperature higher than 60°C or encase them appropriately with a non-combustible material. Special boxes are available on the market. Please contact us for further advice.

2. TECHNICAL CHARACTERISTICS

CHARACTERISTIC	METHOD/STANDARD	
Total thickness	EN 823	7 mm
Dimensions of the roll	EN 822	1,25 m x 25,00 m
Roll surface area	-	31,25 m ²
Number of aluminium films	-	2
Thickness of aluminium	-	12 µm
Number of bubble films	-	2
Thickness of polyethylene	-	150 µm
Surface density	EN 1602	373 g/m ²
Index of resistance to water vapour diffusion	EN 12086 conditions B	12 µ
Intrinsic thermal strength	EN 12667	0,20 m ² .K/W
Emissivity	Test CSTB	5%
Thermal strength between 2 unventilated air gaps of 20 mm		
In horizontal flux	EN ISO 6946	1,50 m ² .K/W
In vertical flux	EN ISO 6946	1,10 m ² .K/W
Equivalent thermal conductivity between 2 unventilated air gaps of 20 mm		
In horizontal flux	EN ISO 6946	0,031 W/m.K
In vertical flux	EN ISO 6946	0,043 W/m.K
Resistance to peeling	EN ISO 11339	F _p = 10 N
Tensile strength	EN 1608	σ _t = 388 kPa
Resistance to tearing (nail shank)	EN 12310-1	σ _t = 132 kPa
Fire classification	EN 13501-1	Ds ₂ d0

3. INSTALLATION METHOD

3.1 GENERAL

Vapreflex is a vapour barrier which provides additional insulation with a very high reflective power. It should always be fitted on the inside, i.e. the warm side, as a complement to additional insulation.

3.1.1. TIGHTNESS TO WATER VAPOUR AND AIR

To protect the conventional insulation from water vapour and to limit energy losses, Vapreflex® must form a tight skin. This is easy to achieve. Vapreflex® should be unrolled across the whole area of the building, on the warm side. It can be unrolled horizontally or vertically according to the orientation of the frame and it should be provisionally fixed in place with 14 mm clips. The Vapreflex® strips should overlap one another by 50 mm. 75 mm Aluthermo® adhesive is applied to achieve tightness. Once it has bonded, the adhesive should be rubbed over with a dry cloth to ensure complete adhesion. As Vapreflex is heat bonded over its whole area, cuts can be made anywhere. It can be cut with a standard cutter.

3.1.2. UNVENTILATED AIR SPACES

To maximise Vapreflex®'s insulating power with respect to radiant energy exchanges, it should be fitted between two unventilated air spaces of at least 20 mm. The unventilated air spaces are created on the outside by combining Vapreflex® with conventional insulation, and on the inside by the finishing coat (plasterboard, wood panelling, etc.). Vapreflex® is always stretched and clipped to its support. In straight sections the distance between clips should not exceed 200 mm. At right-angles to junctions between widths, returns on purlins or floors, clip every 50 mm.

3.2 APPLICATION ON ROOFS OR VERTICAL WALLS

3.2.1. GENERAL PRINCIPLES

Before installing Vapreflex®, carefully check that the conventional insulation has been correctly fitted. In particular, check beforehand how the 20 mm air space between the conventional insulation and Vapreflex® will be formed:

- Either the conventional insulation does not fill the whole height of the rafter, and due to its composition, it is not likely to settle (refer to the manufacturer's information). In this case, Vapreflex® can be unrolled directly below the rafters, provided that the distance between Vapreflex and the conventional insulation is at least 20 mm.

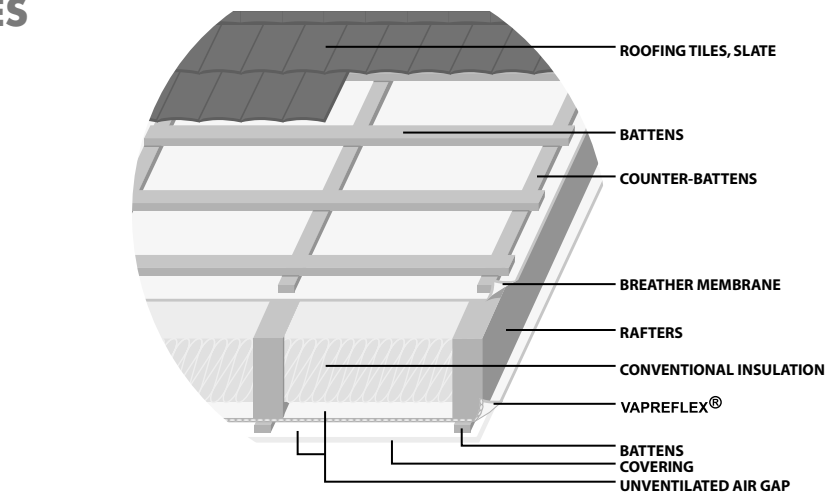

- Or the conventional insulation fills the whole height of the rafter, or due to its composition, it is likely to settle (refer to the manufacturer's information). In this case, before fitting Vapreflex®, lathing must be carried out, using laths not less than 24 mm thick to create the air space. Lathing should be done perpendicular to the rafters.

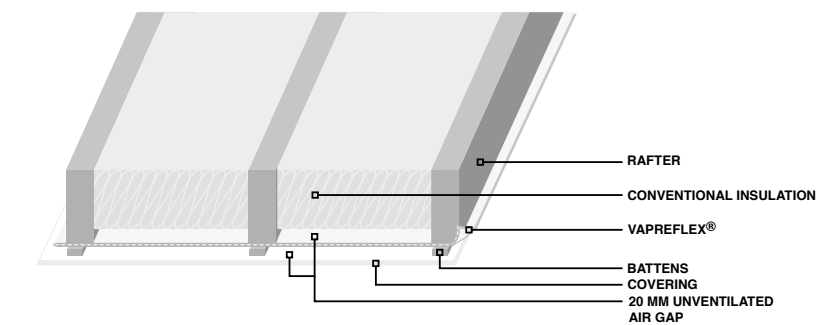

The first strip of Vapreflex® is then unrolled horizontally or vertically, according to the orientation of the frame, correctly stretched and provisionally fixed in place with 14 mm clips.

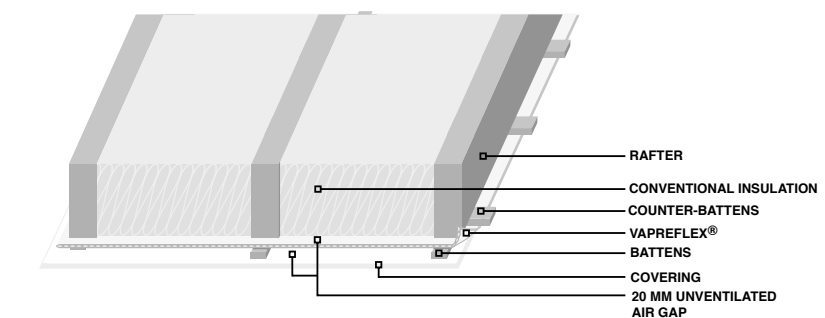

Further strips of Vapreflex® are then put in place with an overlap of not less than 50 mm, and 75 mm Aluthermo® adhesive is applied to achieve tightness.